

Aantal Consoles volgens VDI 6036 - Nombre de Consoles selon VDI 6036  
 Number of Brackets according to VDI 6036 - Anzahl der Konsolen nach VDI 6036

Betonnen Muur* - Paroi en Béton* - Concrete Wall* - Betonwand*			
H	300 - 400		500-950
VDI 6036	class 1-2	class 3	class 1-2-3
L 400	2	2	2
500	2	2	2
600	2	2	2
700	2	2	2
800	2	2	2
900	2	2	2
1000	2	2	2
1200	2	2	2
1400	2	3**	2
1600	2	3**	2
1800	3	3	3
2000	3	3	3
2200	3	4**	3
2400	3	4**	3
2600	3	4**	3
2800	3	4**	3
3000	3	4**	3

- (\*) Voor montage in andere wanden:  
 - Mogelijk dienen andere bouten en pluggen gebruikt te worden.  
 - Het aantal consoles om aan de benodigde klasse te voldoen kan veranderen.
- (\*\*) Bijkomende console(s) vereist om aan klasse 3 te voldoen.  
 Contacteer ons voor meer informatie.
- (\*) Pour montage dans d'autres parois:  
 - Il peut être nécessaire d'utiliser d'autres vis et chevilles.  
 - Le nombre de consoles pour être conforme à la classe requise peut varier.
- (\*\*) Console(s) supplémentaire(s) nécessaire(s) pour être conforme à la classe 3.  
 Veuillez nous contacter pour plus d'informations.
- (\*) For mounting in other types of walls:  
 - It may be necessary to use other screws and plugs.  
 - The number of brackets may vary in order to fulfill class 3.
- (\*\*) Additional bracket(s) required to fulfill class 3.  
 Contact us for more information.
- (\*) andere Wandmateriale:  
 - andere Schrauben und Dübel sind möglicherweise erforderlich.  
 - die Anzahl der notwendigen Konsolen zur Erfüllung der Anforderungen der Klasse kann sich ändern.
- (\*\*) zusätzliche Console(n) sich erforderlich zur Erfüllung der Anforderungen von Klasse 3. Wir stehen zur Verfügung für weitere Informationen.

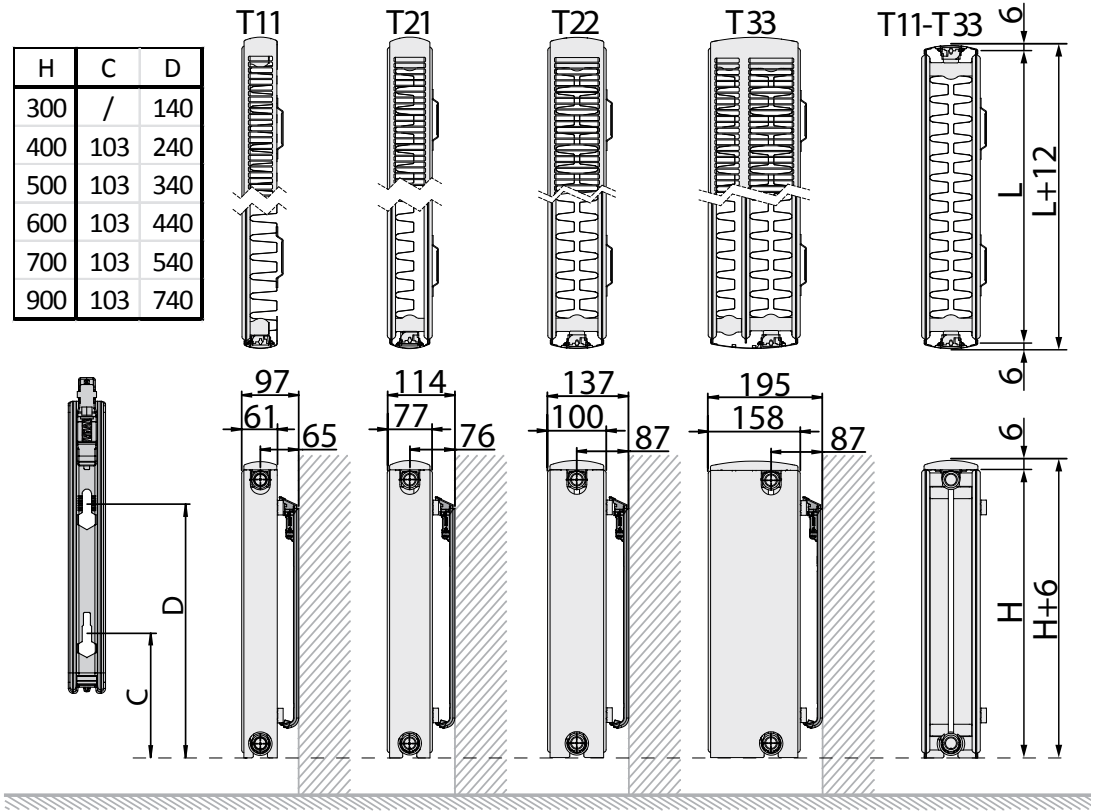

L	T11		T21 - T33	
	A	B	A	B
400	117	/	133	/
500 - 1600	150	/	133	/
1800 - 3000	150	17	133	0

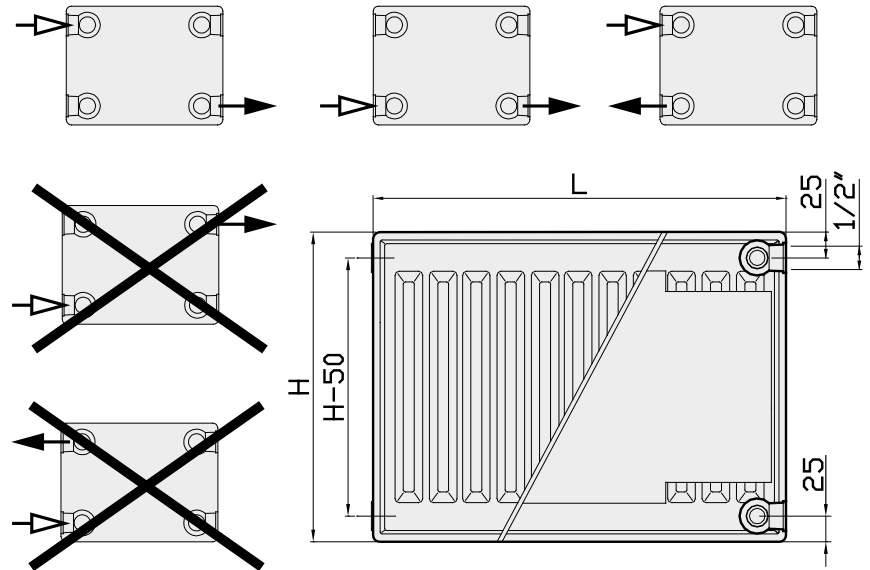
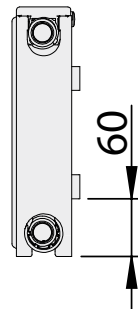
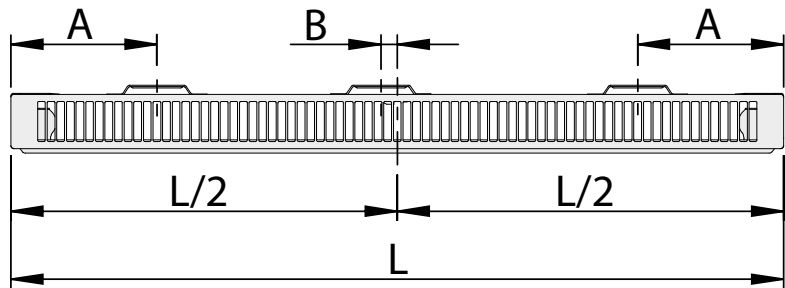

① \*L >= 1800

